



Original Instruction Manual

SWA

Asparagus washing and cutting machine

Manufacturer:
HMF Hermeler Maschinenbau GmbH
Dipl. Wirt. Ing. Thomas Hermeler
Lohmannstr.4
D-48336 Sassenberg-Füchtorf
Phone: 0049 (0) 54 26 / 53 84
Fax: 0049 (0) 54 26 / 53 85
Mail: verkauf@hmf-hermeler.de
Website: www.hmf-hermeler.de

Table of contents

	Page
1. Introduction	3
2. Content	3
3. General remarks	3
3.1 Special attention	3
3.2 Description of the type plate	4
4. Safety instructions	5
4.1 Safety and accident prevention instructions	8
5. Commissioning	8
6. Application	8
7. Operation	9
8. Blade change	9
9. Tensioning the belt	9
10. Notes on misuse of the machine	10
11. Maintenance & Care	10
11.1 Cleaning schedule	11
12. Information on DIN VDE	12

1. Introduction

This instruction manual is valid for the washing and cutting machine SWA. It is primarily intended for the operator and provides information on the use, setting and operation of the machine. Make this instruction manual is available to all persons who work with the machine. Texts and pictures are kept neutral as far as possible. Attention is drawn to differences by means of picture headings or text notes.

Manufacturer:
HMF Hermeler Maschinenbau GmbH
Lohmannstr. 4
D-48336 Sassenberg-Füchtorf
Phone: 0049 (0) 5426 5384
Fax: 0049 (0) 5426 5385
Mail: verkauf@hmf-hermeler.de

2. Content

Read this instruction manual carefully and completely before working with the SWA. Follow the advice for the correct care and maintenance of your machine and you will achieve constant readiness for operation and a long service life for your machine.

3. General notes

3.1 Special attention

The information in this instruction manual must be read, understood and observed by all persons who use, operate, maintain or check these machines in order to prevent hazards. In particular, read the section "Safety instructions".

The use of spare parts, accessories and additional equipment that do not originate from HMF and have not been tested and approved by HMF, that negatively change the design properties of the HMF machine or its functional capability and thereby impair active and/or passive driving safety and occupational safety (accident prevention) is not permitted.

HMF accepts no liability whatsoever for damage caused by the use of non-HMF original parts, accessories and ancillary equipment. Technical specifications, dimensions and weights are not binding. We reserve the right to make changes in the course of technical development and errors.

3.2 Description of the type plate

The serial number of the machine, the type and the year of manufacture are stamped on the type plate. This type plate is normally located in or on the control cabinet.

In the case of a spare parts order, please provide us with the following information:

1. Serial number
2. Type
3. Manufacture year



4. Safety instructions

Please read and observe this instruction manual and the safety instructions before you start working with the machine!

Labelling of warnings and hazards

In this instruction manual, we have marked all passages concerning your safety and the safety of the machine with the following symbols. Pass on all safety instructions to other users as well!



Danger!

Labelling of instructions which, if not observed, pose a risk to the life and limb of the operator or his fellow human beings.

+ Measures to avoid danger



Achtung!

Labelling of instructions which, if not followed, may result in damage to the machine

+ Measures to avoid danger to the machine



Note!

Labelling of notes that enable a more effective and economical use of the machine



Environment!



Labelling of notes which, if not followed, may present hazards to the environment.

There is an environmental hazard if environmentally hazardous substances (e.g. oils, foils, etc.) are not handled properly and/or disposed of.

The warning and information signs attached to the machine provide important information for safe operation. Observance of these instructions is for your own safety.

Generally valid:

- a) Strictly follow warning signs and information signs!
- b) Pass on all safety instructions to other users as well!
- c) Keep warning signs and information signs in good condition, replace if necessary!

	<p>Before commissioning, read and observe the instruction manual and the safety instructions!</p> <p>Switch off the engine and remove the ignition key during maintenance and repair work!</p>
	<p>Attention Electrical voltage.</p>
	<p>Do not touch machine parts until they have come to a complete stop.</p> <p>During operation and when the engine is running: Do not open or remove the guard. Never reach into the rotating parts.</p> <p>Do not stand near the rotating parts or touch moving machine parts! Wait until they have come to a complete standstill!</p>



There is a risk of crushing!



Caution! Danger from ejecting parts when the machine is running.

Keep a safe distance!



Do not stay within the swivel range of the implements!

4.1. Safety and accident prevention instructions

- In addition to the information in this instruction manual, observe the general safety and accident prevention instructions.
- Test all functions of the appliance before starting work in order to be prepared for work.
- Keep sufficient distance from the rotating blade while working!
- Do not reach under the blade cover.
- Protect the motor and switch from splashing water when cleaning!
- During cleaning, maintenance and repair work the machine must be switched off and disconnected from the power supply!
- Do not deactivate the electrical limit switches!
- All safety devices must always be properly fitted.
- It is forbidden to reach under the conveyor belt during sorting!
- Caution, there is a risk of crushing when closing the cover and the blade guard! The SWA should stand on firm, level ground, but may have a slight inclination to the right!
- Caution! Standing blades are also very dangerous and can cause injuries; therefore wear safety gloves when working on the cutting unit!
- Work on the electrical system may only be carried out by a qualified electrician!

5. Commissioning

To take full advantage of your new machine, please read and follow this instruction manual before using your machine. Before using the machine, check that it has been delivered complete. Remove the packaging carefully and completely.

Familiarise yourself with the technical instruments. Please always observe the safety instructions. We must reject warranty claims resulting from improper handling!

6. Application

The Hermelers asparagus washing and cutting machine SWA may only be used as intended. With the SWA, freshly harvested asparagus can be cut to length, washed and sorted by hand into individual quality classes.

7. Operation

The asparagus is washed in a single operation and cut to a length of 22 cm to 28 cm, depending on the stop setting. Six to nine variable spray nozzles and a large washing brush guarantee optimum cleaning of the asparagus.

The asparagus is hung with the head on the left-hand side (small drive volume) when cutting. The nubbed belt transports the asparagus past the rotating blade, which cuts it to the desired length. No more than two thirds of the nubbed section of the conveyor belt should be covered with asparagus so that the asparagus can swivel under the washing brush. The height of the washing brush can be adjusted.

On the right-hand side of the machine, the asparagus is sorted by hand.

8. Blade change

To be able to change the blade, the blade guard on the machine must be swivelled to the side. Unscrew the screw (1) to separate the blade holder from the blade shaft. The nuts on the bearing shell (2) are also unscrewed. The blade holder and bearing (1+2) must be removed from the disc (3). The circular blade (4) is now loose in the washing tunnel and can be replaced. The blade is fitted in reverse order.

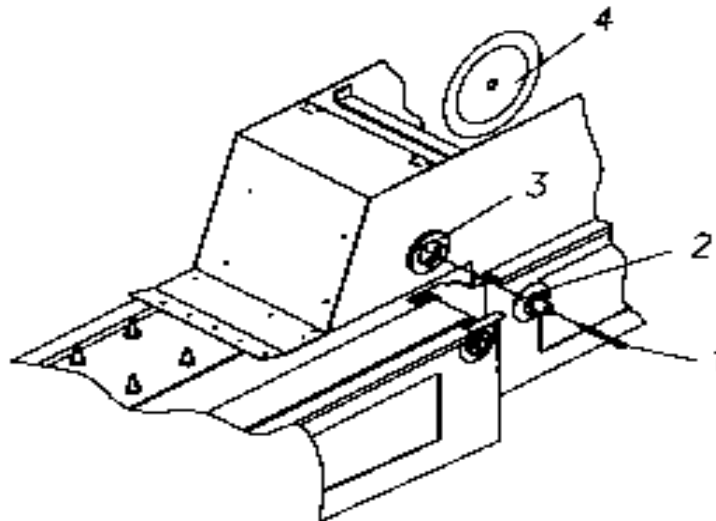

9. Tensioning the belt

The drive belt (1) and the nubbed belt (2) have already been adjusted at the factory. The belts should always be tensioned evenly on both screws (3) of a deflection pulley.

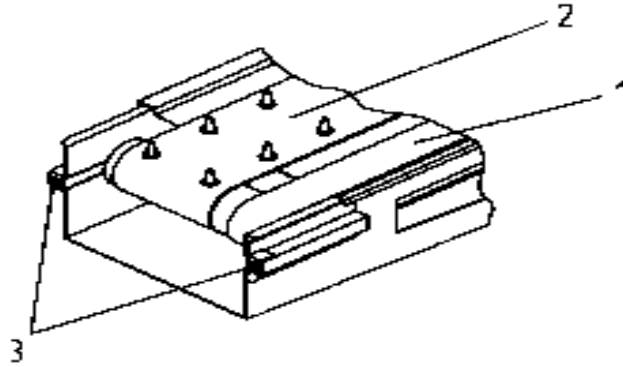

ATTENTION:

The belt must first be tensioned on the sorting side, then on the application side!!!

10. Notes on misuse of the machine

No persons may be carried on the machine.

11. Maintenance & Care

- To ensure trouble-free operation, the drive and deflection rollers must be cleaned of asparagus leaves with water every hour. This prevents the belts from skewing.
- Maintenance-free ball bearings ensure that the machine runs smoothly.
- The bearing journal for the intermediate gear wheel on the motor must be lubricated with cooking oil at the start of the season.
- At the end of the season, the conveyor belts should be slightly slackened.
- Protect the motor and switch from moisture.

11.1 Cleaning schedule

	daily	weekly	before / after the season
<ul style="list-style-type: none"> - Clean the conveyor belt - Rinse with water and clean it of dirt 	X		
<ul style="list-style-type: none"> - Get the conveyor belt wet - Clean the belt with a brush and water - Rinse it with clear water 		X	
<ul style="list-style-type: none"> - Clean the inside of the machine with water 	X		
<ul style="list-style-type: none"> - Check nozzles for contamination and clean them 		X	
After season:			
<ul style="list-style-type: none"> - Clean the entire machine thoroughly with standard household cleaning products - Rinse very thoroughly Bearing grease 			X

12. Information on DIN VDE

Citations:

DIN VDE 0100 Part 705

3. Protection against dangerous body currents

- 3.1 Circuits with sockets in the TN, TT, IT system must be protected by residual current devices with a rated residual current I_n less than or equal to 30mA.
- 3.2 For protective measures in case of indirect contact by automatic disconnection of the power supply, the agreed limit of the permanently permissible touch voltage is $U_L=25V$ AC rms or 60V DC (harmonicfree) for areas intended for animal husbandry. The maximum switch-off time until the supply is interrupted is specified in a table in preparation.

4. Protection against thermal influences

- 4.1 Fire protection
Fire protection must be ensured by a residual current device with an I_n less than or equal to 0.5A

5. Selection and installation of electrical equipment

- 5.3 Switching and control devices

Note: It is recommended to protect final circuits by a residual current device with the lowest possible rated residual current, preferably up to 30mA, at which no false tripping occurs

Explanations/explanations

Re 3.2:

If units are permanently connected, a residual current device with an I_n of up to 0.5 A may also be used (see 4.1).

Re 3.3:

In agricultural installations without livestock, the permissible touch voltage is $U_L=50V$ AC rms or 120V DC (harmonic-free) in accordance with DIN VDE 0100 Part 410

Re 4:

No residual current circuit breaker with a tripping current greater than $I_n=0.5A$ may be used.

Re 5.3:

This recommendation is intended for systems in which the residual-current device does not trip during fault-free operation. However, since leakage currents of electronic devices and residual-current devices can lead to false tripping, residual-current devices with a higher tripping current may also be used.

Furthermore, manufacturers of frequency converters recommend the use of all-current sensitive residual current devices.

Additional note:

A residual current device with a certain tripping current must have tripped at this residual current. This does not mean, however, that a residual current device with an $I_n = 30mA$, for example, will only respond above 30mA.

Due to the design, a residual current of 20mA can already cause the RCD to switch off.